

EHD935 eZ.HD Series

720p Analog High Definition

True Day/Night Outdoor IR Dome Vandal Camera

User's Manual



EverFocus[®]

Copyright © EverFocus Electronics Corp,

Release Date: Nov., 2014

Precautions

1. **Do not install the camera near electric or magnetic fields.** Install the camera away from TV/radio transmitters, magnets, electric motors, transformers and audio speakers since the electromagnetic fields generated from these devices may distort the video image or otherwise interfere with camera operation.
2. **Never disassemble the camera beyond the recommendations in this manual nor introduce materials other than those recommended herein.** Improper disassembly or introduction of corrosive materials may result in equipment failure or other damage.
3. **Try to avoid facing the camera toward the sun.** In some circumstances, direct sunlight may cause permanent damage to the sensor and/or internal circuits, as well as creating unbalanced illumination beyond the capability of the camera to compensate.
4. **Keep the power cable away from water and other liquids and never touch the power cord with wet hands.** Touching a wet power cord with your hands or touching the power cord with wet hands may result in electric shock.
5. **Never install the camera in areas exposed to oil, gas or solvents.** Oil, gas or solvents may result in equipment failure, electric shock or, in extreme cases, fire.
6. **Cleaning.** For cameras with interchangeable lenses, do not touch the surface of the sensor directly with the hands. Use lens tissue or a cotton tipped applicator and ethanol to clean the sensor and the camera lens. Use a damp soft cloth to remove any dirt from the camera body. Please do not use complex solvents, corrosive or abrasive agents for cleaning of any part of the camera.
7. **Do not operate the camera beyond the specified temperature, humidity or power source ratings.** This camera is suitable for indoor operation only. Use the camera at temperatures within $-40^{\circ}\text{C}\sim 50^{\circ}\text{C}$ ($-40^{\circ}\text{F}\sim 122^{\circ}\text{F}$) and humidity less than 80%; this device is not rated as submersible. The input power source is 12VDC or 24VAC. Be sure to connect the proper + / - polarity and voltage, as incorrect polarity or too high a voltage will likely cause the camera to fail, and such damage is not covered by the warranty.
8. **Mounting.** Use care in selecting a solid mounting surface which will support the weight of the camera plus any wind, snow, ice or other loading, and securely attach the camera to the mounting surface using screws and anchors which will properly support the camera. If necessary (e.g. when mounting to drop ceilings) use a safety wire to provide additional support for the camera.

Safety Notice

Federal Communication Commission Interference Statement

This equipment has been tested and found to comply with the limits for a Class A digital device, pursuant to Part 15 of the FCC Rules. These limits are designed to provide reasonable protection against harmful interference in a residential installation. This equipment generates uses and can radiate radio frequency energy and, if not installed and used in accordance with the instructions, may cause harmful interference to radio communications. However, there is no guarantee that interference will not occur in a particular installation. If this equipment does cause harmful interference to radio or television reception, which can be determined by turning the equipment off and on, the user is encouraged to try to correct the interference by one of the following measures:

- Reorient or relocate the receiving antenna.
- Increase the separation between the equipment and receiver.
- Connect the equipment into an outlet on a circuit different from that to which the receiver is connected.
- Consult the dealer or an experienced radio/TV technician for help.

FCC Caution: Any changes or modifications not expressly approved by the party responsible for compliance could void the user's authority to operate this equipment.

This device complies with Part 15 of the FCC Rules. Operation is subject to the following two conditions: (1) This device may not cause harmful interference, and (2) this device must accept any interference received, including interference that may cause undesired operation.



ATTENTION! This is a class A product which may cause radio interference in a domestic environment; in this case, the user may be urged to take adequate measures.↵



This Product is RoHS compliant.↵



WEEE↵

Your EverFocus product is designed and manufactured with high quality materials and components which can be recycled and reused. This symbol means that electrical and electronic equipment, at their end-of-life, should be disposed of separately from your household waste. Please, dispose of this equipment at your local community waste collection/recycling centre. In the European Union there are separate collection systems for used electrical and electronic product.↵
Please, help us to conserve the environment we live in!

Contents

1. Introduction.....	5
1.1 Packing List	5
1.2 Features	5
2. Cable Description.....	6
3. Installation	7
3.1 Installation and Adjustment	7
4. Configuration in the OSD Menu.....	13
5. Specifications.....	17

1. Introduction

Get incredible performance in bright light or low light environments, and the resolution listed in the specification from the actual camera you install. To take full advantage of the amazing resolution available from this advanced imaging technology, the EverFocus eZ.HD Series EHD935 uses a vari-focal lens together with 1/2.8" SONY 1.37M pixels CMOS to deliver 720p high resolution. Combined with a useable native low light sensitivity of 0.08lux without using digital slow shutter and **28 LEDs** with range of 30m/100feet or more. The camera truly provides HD images without compromising its 720p video quality, Digital Wide Dynamic Range for clear color images in the most challenging of bright or unbalanced scene lighting conditions, plus true day/night IR enhanced images in low light with guaranteed ZERO ghosting. The EHD935 with its 3-axis rotation design allows wall or ceiling mounting flexibility in an **IP67 weather resistant, vandal proof dome** housing. Your choice of vari-focal 2.8~12mm DC iris lens for easily adjustable field of view; dual voltage operation and a full suite of OSD Menu and DSP functions controllable at the camera (3DNR to save DVR HDD space, privacy masking, mirroring, and much more) This is the camera that you have been waiting for to create analog CCTV systems that produce astounding image clarity in a wide range of outdoor applications at the widest range of light levels. The EHD935 supports both NTSC and PAL scanning systems, which can be switched via OSD.

1.1 Packing List

- Camera Body x 1
- User Manual x 1
- Test Lead x 1
- Template Plate x 1
- Adapter Plate x 1
- Desiccant Bag x 1
- Rubber Plate x 1
- Screw x 4
- Screwdriver x 1
- Plastic Anchor x 4
- DC Power Pigtail Cable x 1
- Hexagon Wrench x 1
- Quick Installation Guide x 1

1.2 Features

- 720p with high flexibility and performance for astounding image
- 1/2.8" SONY 1.37M pixels CMOS, very low light sensitivity
- Vari-focal 2.8~12mm DC iris lens to captures the desired field of view
- 28 IR LEDs for 30m/100feet range -depending on scene IR reflectivity
- D-WDR to improve the visibility under high contrast scene

- Provides 3D Noise Reduction ensures less blurry moving subjects, vivid and high SN ratio images even under low light environment
- Weather resistant IP67 and built-in heater
- Support 720p & 960H analog signal output, which can be easily switched by OSD
- Convenient speedy-mount base plate easily attaches to surface, camera attaches to plate with machine screw

2. Cable Description

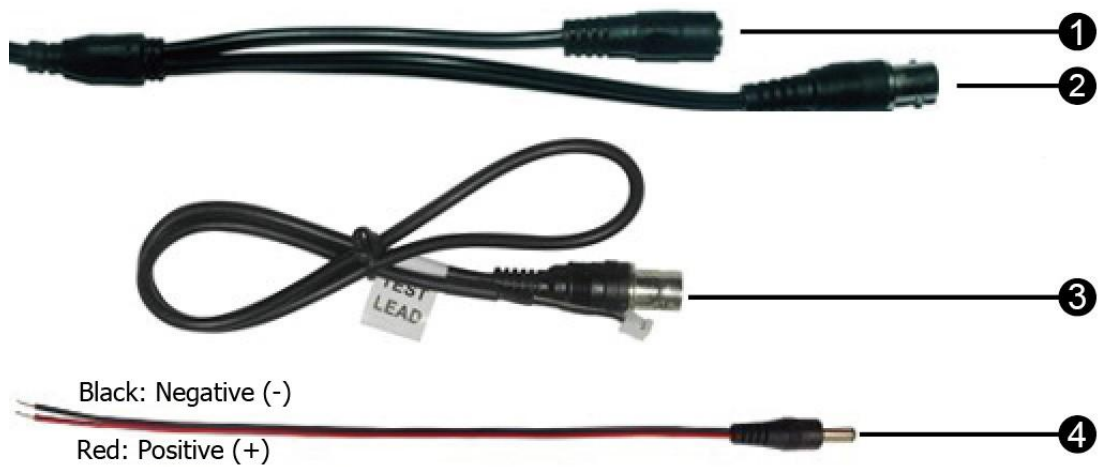

No.	Name	Descriptions
1	Power Cable	Connect to a 12VDC or 24VAC power source.
2	Dual Video Output	720p and 960H output, using a 75 Ohm BNC-type coaxial cable.
3	Test Lead	Connect to a monitor for setting image aim and focus.
4	DC Power Pigtail Cable	Optional power pigtail cable. The red wire is positive (+); while the black wire is negative (-).

3. Installation

3.1 Installation and Adjustment

1. For Ceiling Mount / Wall Mount users: Stick the **Template Plate** on the position where you want to attach the camera, drill the four holes on the **Template Plate** for screwing the **Adapter Plate** with the supplied **Screws** and **Anchors**.

Drill the hole in the centre of the template plate only if you want to wire the cables through the wall / ceiling. Insert the supplied four **Anchors** into the holes.

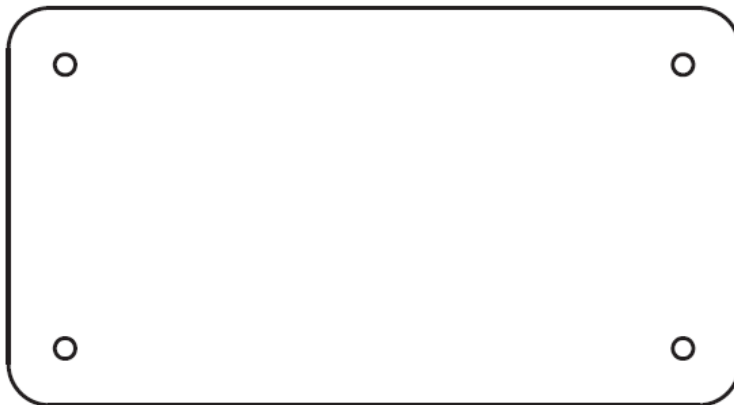

2. Remove the Cover Cap, unscrew the four screws using the supplied **Hexagon Wrench**.

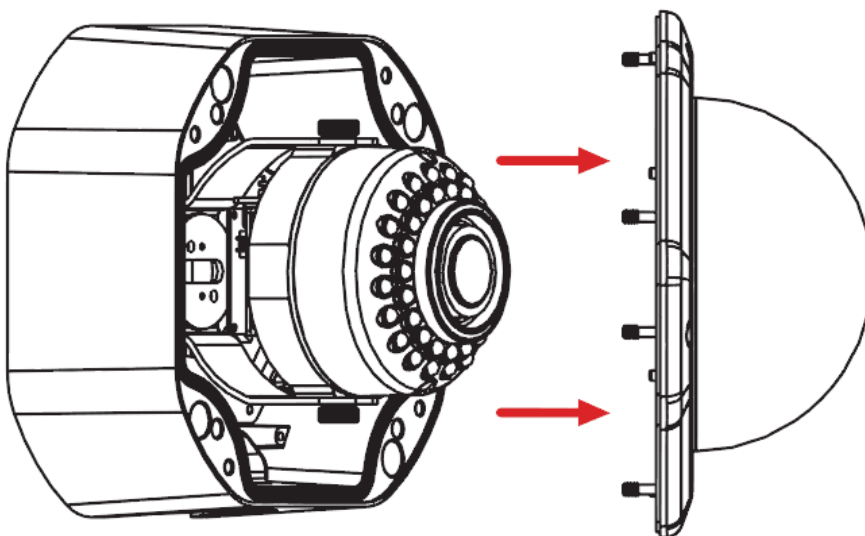

3. Remove the **Adapter Plate** from the camera and screw to the wall/ceiling with supplied **Screws**, then fasten the camera to the **Adapter Plate**.

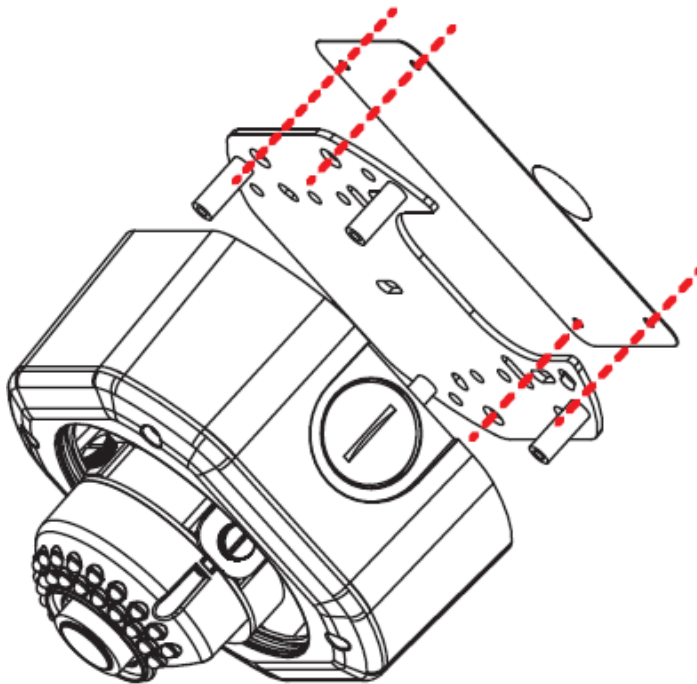

4. If you want to wire the cable through the side of the camera, follow the steps below:
 - a. Remove the Circle Plate from the camera. You can simply loosen the Circle Plate using a coin.

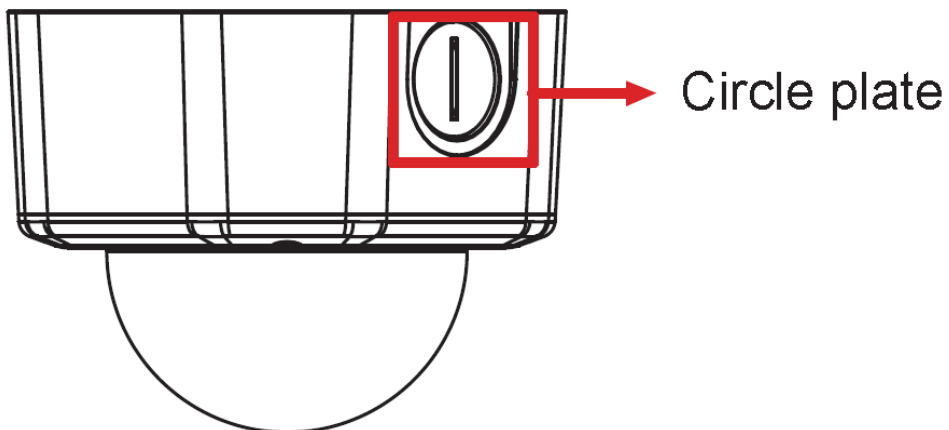

- b. Run the cable through the Cable Conduit.

- c. Use the supplied **Rubber Plate** to firm the cable and then tightly push the **Rubber Plate** to the Cable Conduit.

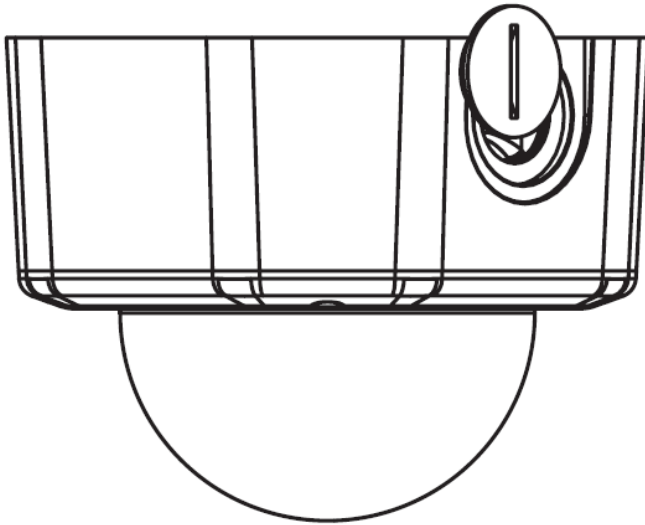

- 5. You can optionally mount the camera using an L-Shaped Mounting Bracket.

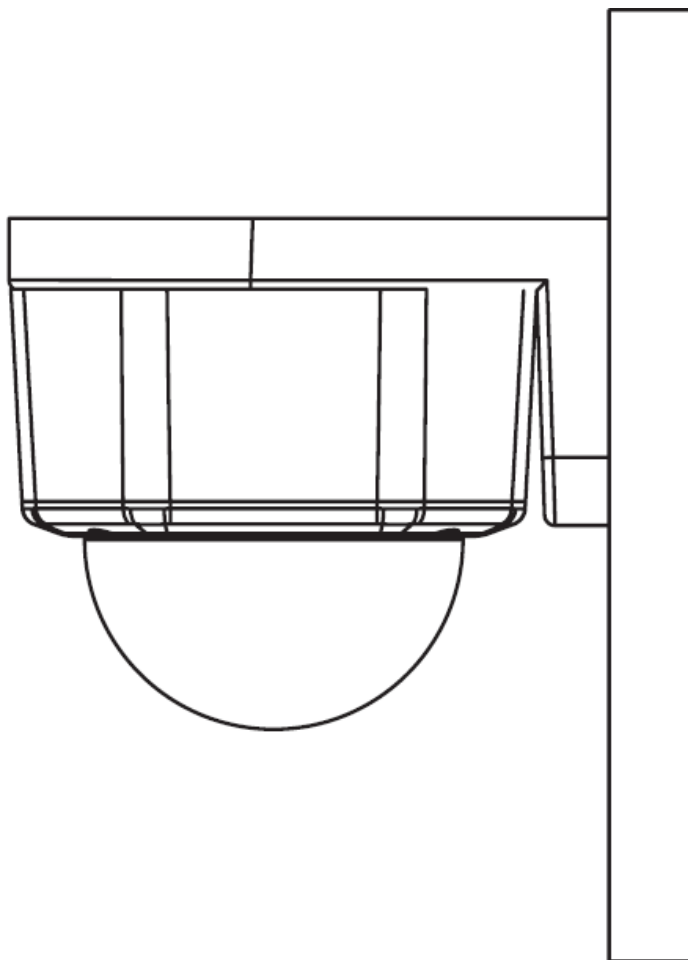

6. Connect the camera to a AHD DVR or a portable monitor with the 12VDC or 24VAC power source using the supplied **DC Power Pigtail Cable** or a power adapter.

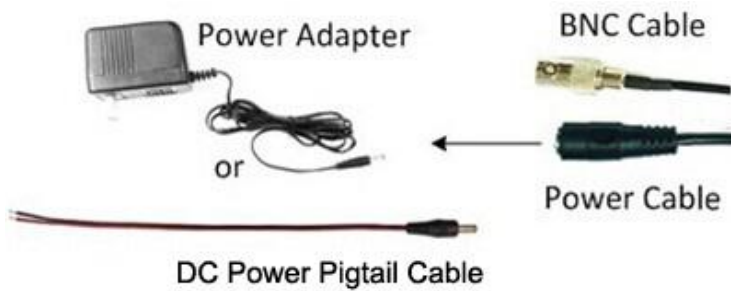

7. Using the **Test Lead** for viewing the video image while adjusting camera angles. You can also use the OSD Menu Joystick to configure camera settings.
 - a. Adjust camera angles by tilting or rotating the camera.

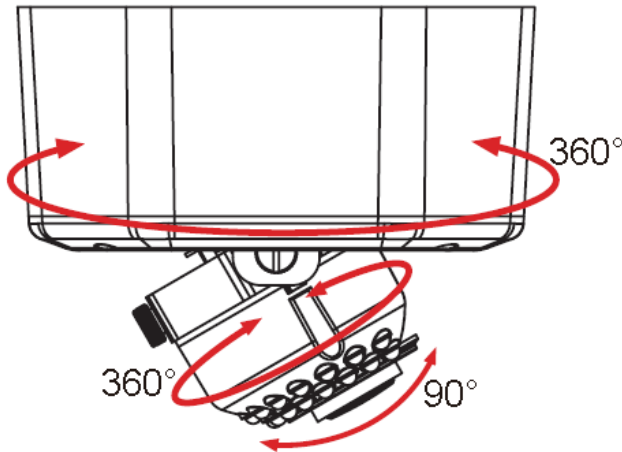

- b. Configure the camera settings using the OSD Menu Joystick, connect one end of the **Test Lead** to the Test-Out connector on the camera module and the other end to the portable monitor.

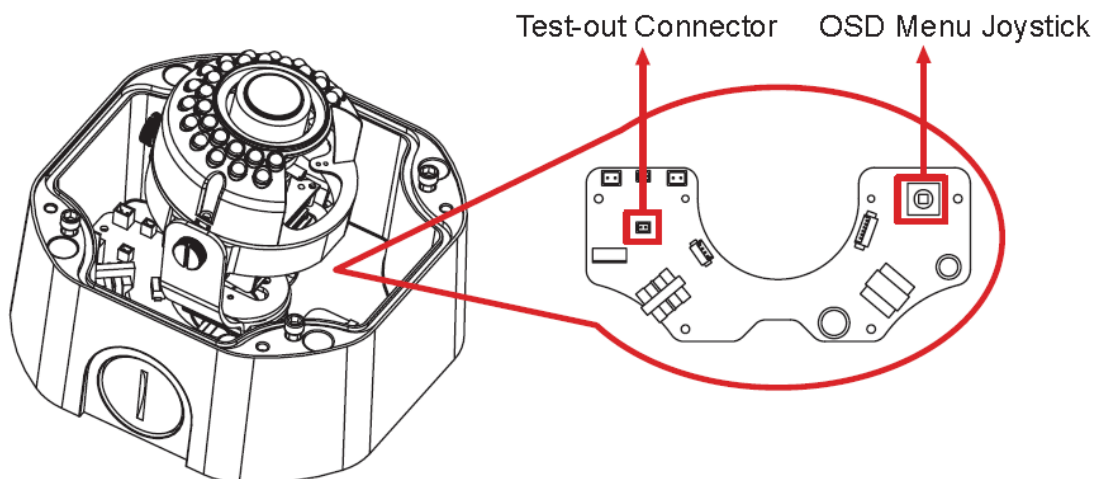

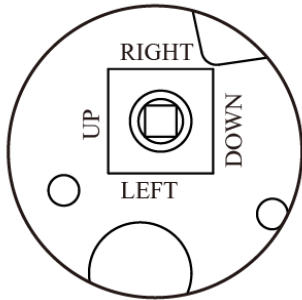

- Push the Joystick up / down to select among menu items.
- Push the Joystick left / right to adjust the level of the selected item.
- Press the Joystick to enter the submenu or exit the OSD Setup Menu.

Note: The function button is not only for direction control, also for switching Video format and Video output. Please follow the detailed instruction as below:

- ✧ Push the joystick "DOWN" button key over 5 seconds to switch video format from PAL to NTSC.
 - ✧ Push the joystick "LEFT" button key over 5 seconds to switch video output from 720p to 960H (720p is the default).
 - ✧ Push the joystick "RIGHT" button key over 5s to switch video output from 960H to 720p.
8. Adjust the Zoom / Focus using the Zoom / Focus screws. Tighten the Zoom / Focus screws using the supplied **Screwdriver**.

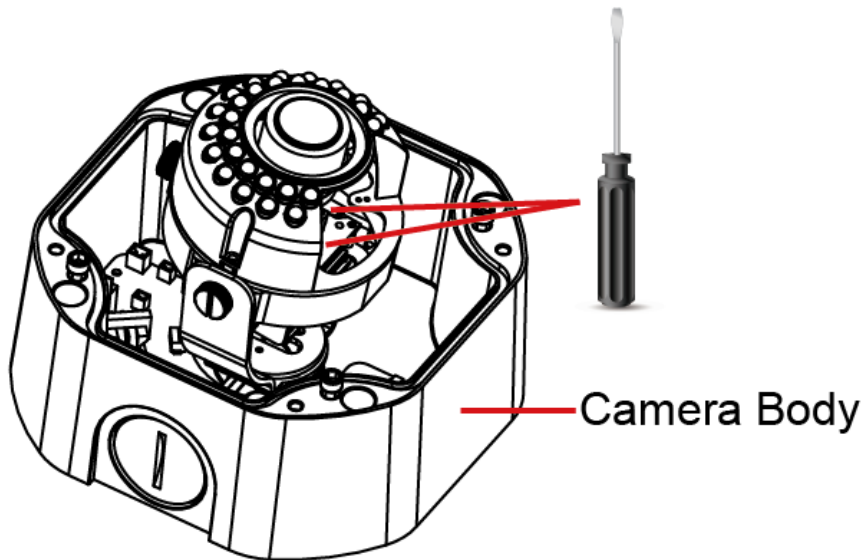

9. Tear apart the outer packing (figure 1) to take out the **Desiccant Bag** (figure 2), then make it folded (figure 3) and put it into the camera housing (figure 4).

Figure 1



Figure 2



Figure 3

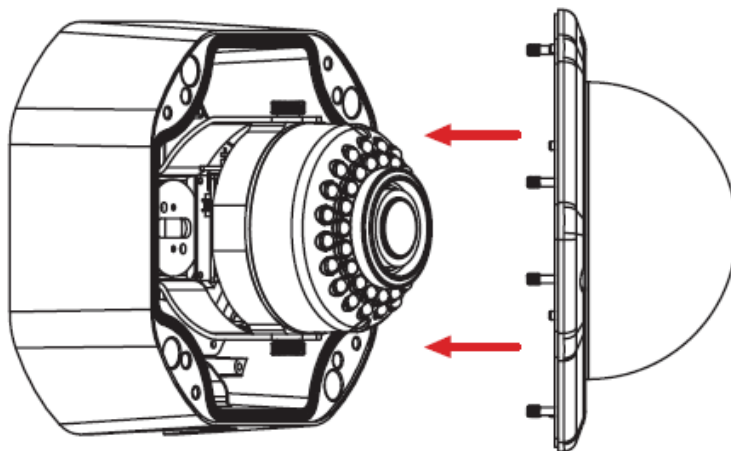

Figure 4



Note: It's recommended to close the cover cap immediately in case of reducing the absorption capacity of the **Desiccant Bag** inside the camera.

10. Screw back the Cover Cap Set Screw using the supplied **Hexagon Wrench**.



4. Configuration in the OSD Menu

You can use the Joystick on the rear panel of the camera to configure camera settings in the OSD menu. For details on the OSD menu structure as below:

No.	Main	Sub Menu	Sub Menu / Function		
1	Lens	DC*	Mode	Indoor	
				Outdoor*	Min Shu.
			Max. Shu.		NTSC: 1/60,FLK,1/240, 1/480,1/1000, 1/2000,1/5000*, 1/10000, 1/50000
				PAL: 1/50,FLK,1/200, 1/400,1/1000, 1/2000,1/5000*, 1/10000, 1/50000	
		Iris Speed	0 – 15(0*)		
Manual					
2	Exposure	Shutter	NTSC: 1/30, 1/60, FLK, 1/240, 1/480, 1/1000, 1/2000, 1/5000, 1/10000, 1/50000, X2, X4, X6, X8, X10, X15, X20, X25, X30, Auto*		
			PAL: 1/25, 1/50, FLK, 1/200, 1/400, 1/1000, 1/2000, 1/5000, 1/10000, 1/50000, X2, X4, X6, X8, X10, X15, X20, X25, X30, Auto*		
		AGC	0 – 15(15*)		
		Sens-up	Off*		
			Auto	Sens-up	X2, X4*, X6, X8, X10, X15, X20, X25, X30
		Brightness	1-100(40*)		
		D-WDR	Off*		
			On	Level	0-8(8*)
		Defog	Auto		
			Auto	Off*	
Pos/Size	Position, Size, ↑, ↓, →, ←				
Gradation	0-2(0*)				
Default					

3	Backlight	Off*					
		BLC	Level	Middle*, High, Low			
			Area	Position, Size, ↑, ↓, →, ←			
			Default				
		HSBLC	Select	Area1*, Area2, Area3, Area4			
			Display	Off			
				On*	Position, Size, ↑, ↓, →, ←		
			Black Mask	On*/Off			
			Level	0-100(20*)			
			Model	All Day*			
Night	AGC Level	0-255(48*)					
Default							
4	White Balance	ATW*					
		AWC→SET					
		Indoor					
		Outdoor					
		Manual	Blue	1-500(50*)			
			Red	0-100(50*)			
		AWB					
5	Day & Night	Ext*	D→N(Delay)	0-60(1*)			
			N→D(Delay)	0-60(1*)			
		Auto	D→N(AGC)	1-255(240*)			
			D→N(Delay)	0-60(1*)			
			N→D(AGC)	1-255(50*)			
			N→D(Delay)	0-60(5*)			
		Color					
		B/W	Burst	Off*/On			
				Off			
			IR Smart	On*	Level	0-15(4*)	
					Area	Position, Size, ↑, ↓, →, ←	
		IR PWM	Off				
0-100(100*)							
6	NR	2DNR	Middle*/Low/Off/High				
		3DNR	Middle*/Low/Off/High				
7	Special	Cam Title	Off*				
			On	0123456789ABCDEFGHIJKLMN OPQRSTUVWXYZ▶→ ← ↑ ↓ () ^ _ █ /=&:~.,.			

		D-effect	Freeze	Off*/On				
			Mirror	Off*, Mirror, V-flip, Rotate				
			Neg. Image	Off*/On				
		Motion	On	Off*				
				Select	Area1*,Area2,Area3,Area4			
					Display	On*	Position, Size, ↑, ↓, →, ←	
				Off				
				Sensitivity	0-100(64*)			
				Color	Green*, Blue, White, Red			
				Trans	1.00*,0.75,0.50, 0.25			
				Alarm	View Type	Off, Block, Outline, All*		
					OSD View	On*/Off		
					Alarm Out	On*/Off		
					Alarm Sig	High*, Low		
					Time	1-15(3*)		
				Default				
		Privacy	On	Off				
				Select	Area1*,Area2,Area3,Area4			
					Display	Off		
						Color*	Position, Size, ↑, ↓, →, ←	
						Mosaic	Position, Size, ↑, ↓, →, ←	
				Inv	Position, Size, ↑, ↓, →, ←			
				Color	White*, Black, Red, Blue, CYAN, Yellow, Green			
				Trans	1.00*,0.75,0.50, 0.25			
		Default						
		Language	ENG*/CHN1/CHN2/GER/FRA/ITA/SPA/POL/RUS/POR/NED/TUR					
		Defect	Live DPC	Off				
On*	AGC level			0-255(65*)				
	Level		0-100(100*)					
White DPC	Off							

				On*	Pos/Size	Position, Size, ↑, ↓, →, ←	
					Start	Close the iris then press	
					DPC View	Off*/On	
					Level	0-60(5*)	
					AGC	0-14(14*)	
					Sens-up	x2*, x4, x6, x8,x10, x15, x20, x25, x30	
				Black DPC	On	Off*	
						Pos/Siz	Position, Size, ↑, ↓, →, ←
						Start	Press Enter
						DPC View	Off*/On
		RS485	CAM ID	0-255(1*)			
				ID Display	Off*/On		
					Baud Rate	2400,4800,9600,19200 ,38400	
		8	Adjust	Sharpness	Off		
					Auto*	Level	0-10(6*)
Start AGC	0-255(50*)						
End AGC	0-255(200*)						
CRT/LCD	CRT			Black Level	0-60(0*)		
				Blue Gain	0-100(50*)		
				Red Gain	0-255(50*)		
	LCD*			Gamma	User*,0.45,0.50,0.55,0.60,0.65,0.70,0.75,0.80,0.85,0.90,0.95,1.00		
				Blue Gain	0-100(50*)		
				Red Gain	0-100(50*)		
LSC	Off*/On						
Video. Out	PAL/NTSC						
9	Exit			Save& END /Reset/Not Saved			

5. Specifications

P/N	EHD935
Pickup Device	1/2.8" SONY 1.37M pixels CMOS
Video Format	NTSC and PAL(can be switched via OSD)
Effective Pixels	1280 (H)*720 (V)
Scanning System	Progressive Scan
Sensitivity	0 lux with IR on
S/N Ratio	Over 48 dB (AGC OFF)
Electronic Shutter	AUTO, Manual (X30~1/ 50000), FLK
Video Output	BNC 1.0Vp-p 75Ω
Gamma Correction	0.45
Lens Type	2.8-12mm DC Iris with ICR
BLC	OFF/BLC/HS BLC Selectable
AGC	0~15 Levels
White Balance	ATW/AWC-SET/INDOOR/OUTDOOR/MANUAL/AWB
Sync Mode	Internal
Day/Night	Ext, Auto, Color, B/W
IR LED	28 Units
IR Distance	Up to 30m/100ft. (depending on scene IR reflectivity)
OSD Languages	12-Language
DNR	2DNR/3DNR, Off
DEFOG	Off/Auto(under B/W mode)
D-WDR	On/Off
Sens-up	Off/On(x30~x2)
Mirror	Off, Mirror, V-flip, Rotate
Motion Detection	On/Off for 4 selectable zones
Privacy Mask	On/Off for 4 selectable zones
Environmental	IP67 Weather Resistant
Power Source	12VDC/24VAC
Power Source	12VDC: 9w max./ 24VAC: 15w max.
Operating Temperature	-40°C~50°C / -40°F~122°F
Humidity	Less than 80%
Dimensions	149 x 149 x 125mm / 5.86" x 5.86" x 4.92"
Weight	1500g/3.3lbs
Certifications	CE/FCC/ RoHS

Specifications and designs are subject to change for improving the functionality of this product without notice.

EverFocus Electronics Corp.

EverFocus Taiwan:

12F-1, No.79, Sec. 1, Shin-Tai Wu Road,
Hsi-Chih, New Taipei City, Taiwan
TEL: +886 2 2698 2334
FAX: +886 2 2698 3943
www.everfocus.com.tw
marketing@everfocus.com.tw

EverFocus China - Beijing:

Room 609, Technology Trade Building,
Shangdi Information Industry Base,
Haidian District, Beijing 100085, China
TEL: +86 10 6297 3336~39
FAX: +86 10 6297 1423
www.everfocus.com.cn
marketing@everfocus.com.cn

EverFocus USA - California:

1801 Highland Avenue, Unit A, Duarte, CA 91010,
USA
TEL: +1 626 844 8888
FAX: +1 626 844 8838
www.everfocus.com
sales@everfocus.com

EverFocus Japan:

3F Kuramochi, BuildingII 2-2-3 Koto-Bashi,
Sumida-Ku Tokyo, 130-0022, Japan
TEL: +81 3 5625 8188
FAX: +81 3 5625 8189
www.everfocus.co.jp
info@everfocus.co.jp

EverFocus India:

UBS, 629/1243, 1st Floor, G Block, Behind
Teacher's Colony, Bandra Kurla Complex,
Bandra (E), Mumbai 400 051, India
TEL: +91 22 6726 4500
FAX: +91 22 6726 4518
www.everfocus.in
sales@everfocus.in

EverFocus Europe - Germany:

Albert-Einstein-Strasse 1, D-46446
Emmerich, Germany
TEL: +49 2822 93940
FAX: +49 2822 939495
www.everfocus.de
sales@everfocus.de

EverFocus China - Shenzhen:

4F, No. 2, D4 Building, Wan Yelong
Industrial Park, Tangtou Road, Shiyan,
Baoan, Shenzhen, Guangdong 518101, China
TEL: +86 755 2765 1313
FAX: +86 755 2765 0337
www.everfocus.com.cn
marketing@everfocus.com.cn

EverFocus USA - New York:

415 Oser Avenue, Unit S, Hauppauge, NY 11788, USA
TEL: +1 631 436 5070
FAX: +1 631 436 5027
www.everfocus.com
sales@everfocus.com

EverFocus China - Shanghai:

Room 403, Ruijin Business Center, No.96, Zhaojiabang
Road, Luwan district, Shanghai 200020, China
TEL: +86 21 6471 2229 / 6471 2291
FAX: +86 21 6471 0566
www.everfocus.com.cn
marketing@everfocus.com.cn



Your EverFocus product is designed and manufactured with high quality materials and components which can be recycled and reused. This symbol means that electrical and electronic equipment, at their end-of-life, should be disposed of separately from your household waste. Please, dispose of this equipment at your local community waste collection/recycling centre. In the European Union there are separate collection systems for used electrical and electronic product. Please, help us to conserve the environment we live in!

Ihr EverFocus Produkt wurde entwickelt und hergestellt mit qualitativ hochwertigen Materialien und Komponenten, die recycelt und wieder verwendet werden können. Dieses Symbol bedeutet, dass elektrische und elektronische Geräte am Ende ihrer Nutzungsdauer vom Hausmüll getrennt entsorgt werden sollen. Bitte entsorgen Sie dieses Gerät bei Ihrer örtlichen kommunalen Sammelstelle oder im Recycling Centre. Helfen Sie uns bitte, die Umwelt zu erhalten, in der wir leben!